

The first triple auger horizontal mixer made in Latin America!



Exclusive patented anti-compaction system.

Standard stainless steel coating



Totalmix®

TMR Mixer

The first mixer with three horizontal augers ever launched in Latin America, TotalMix has the unique and patented curved box design, substantially reducing the undesirable effect of feed compaction, which may disturb the rumen functioning of the cattle.

TotalMix offers high quality chopping and mixing performance of any types bulky feedstuffs, from processed roughages to wet, heavy rations, including hay bales (up to 15 kg), as well as agro-industrial residue.

Features

- Equipment built with highest quality steel.
- Special stainless steel bottom coating, which protects the box against abrasion and corrosion.
- Designed and built to last.
- Extra reinforced threaded lower auger is equipped with removable knives.
- Two continuous upper augers (mounted on two support points).
- Uniquely designed sidewalls help to produce a fluffy mix.
- Independent chassis.
- Latest generation planetary drive system.
- Sealed PVC discharge conveyor belt with splits.
- Great ground clearance: highest discharge conveyor in its category.
- Programmable electronic scale is a standard feature.
- Load cells installed on an independent chassis.

Application



Animal Feed with total feed

Number of fed animals

Totalmix Family	Trailed	Truck	Stationary
Dairy	80 – 1.500	1.000 – 2.000	2.000 – 5.00
Beef	500 – 5.000	3.000 – 7.500	4.000 – 10.000



PVC discharge conveyer belt with cleats, moved by hydraulic motor.



Extra reinforced, segmented lower screw with removable knives.



Programmable electronic scale.



Technical features

- The reliability of CASALE brand.
- Lowest power consumption in the three-auger mixer category.
- Longer service life due to resistance against abrasion and oxidation.
- Capacity of producing high roughage TMR.
- Provides a thorough mix and the fluffiest ration among its competitors.
- Average mixing time of 5 minutes.
- Consistency in the feed distribution and zero waste.
- Great discharge flexibility due to its adjustable belt.
- Low downtime rate.
- Great precision weighing the dietary ingredients.



**IT LASTS
LONGER!**

WHY DO CASALE EQUIPMENT LAST LONGER?

- They are designed to be low maintenance;
- The quality and specifications (thickness, chemical composition, hardness) of the raw material and components are above average.

Optional Accessories

- High fluctuation tires 400/60 15.5 (models 65AC and 80C),
- High fluctuation tires 500/60 (models 100AC and 120C).
- Total stainless steel coating (80 AC).
- Scale with USB output.
- Management software.
- Remote weight indicator.
- Upper auger knives set.
- Magnetic plate set.
- Deflector.

Feed Management

- **Programmable electronic scale:** Enables an accurate dosage of all the diet's ingredients, ensuring full use of the nutrients for a bigger production without waste.
- **Management Software (requires scale with USB output):** Allows you to formulate recipes in your computer, and then transfer data to the scale using a pendrive. Enable you to manage cost of cattle feed and inventory of raw material in your feed lot.

Conventional Box

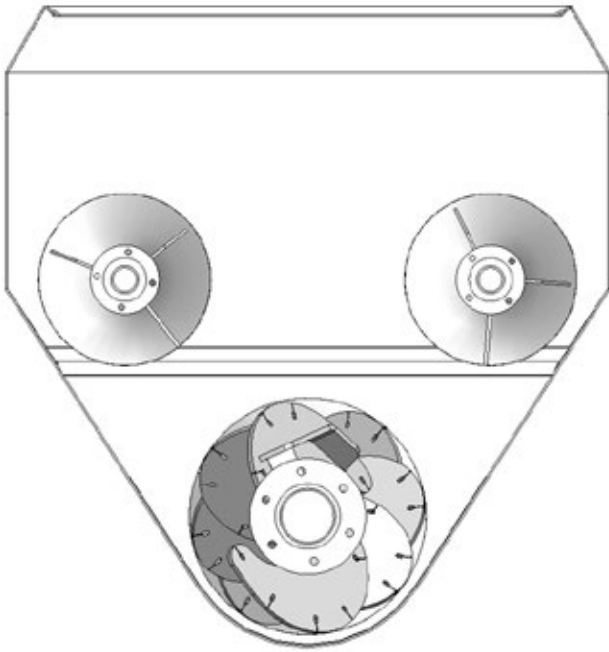

Casale Exclusive Anti-Compaction Box!

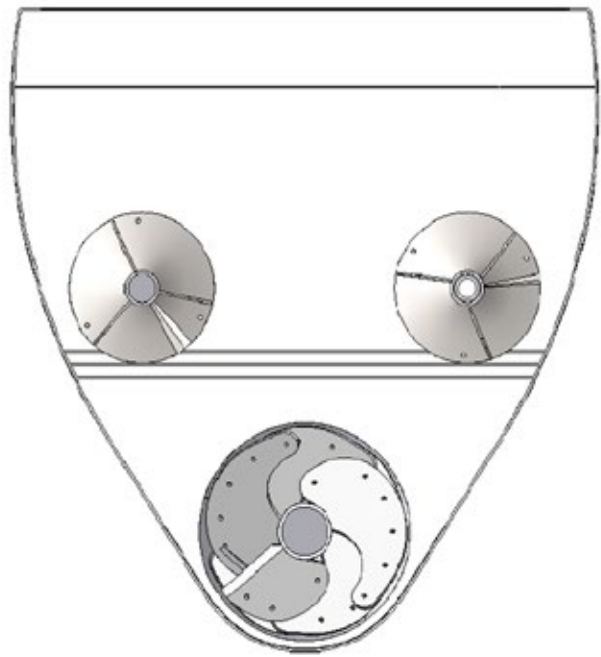

Technical Features

	TMX-25	TMX-40	TMX-65	TMX-80	TMX-100	TMX-120	TMX-150
Actual mixing capacity (m ³)	2,5	4	6,5	8	10	12	15
Screws	3	3	3	3	3	3	3
Door width (mm)	550	700	700	700	810	810	810
Width (mm)	1750	1900	2350	2350	2530	2530	2570
Height (mm)	1900	2130	2290	2680	2780	3100	2910
Length (mm)	3800	4370	5430	5200	6200	6200	7500
Tires	7.50 x 16 (2x)	10.5/65-16R (2x)	360/70 (2x)	900/20 (2x)	900/20 (4x)	900/20 (4x)	900/20 (4x)
Approx. weight (kg)	1560	1990	3000	3550	5300	5950	6750
Minimum power required on PTO (HP)	20	25	30	40	50	65	75
Thickness of the bottom plate with stainless steel (mm)	6,7	8,25	8,25	8,25	9,84	9,84	9,84
Thickness of side plate (mm)	4,76	6,35	6,35	6,35	7,94	7,94	7,94
Thickness of upper screw (mm)	7,94	7,94	7,94	7,94	9,53	9,53	9,53
Thickness of lower screw (mm)	12,7	12,7	19,05	19,05	19,05	19,05	19,05



Get to know our complete product line at:
www.casale.com.br

Telephone: +55 (16) 3411-5000 / +55 (16) 3411-5001 / +55 (16) 98122-4238 /
+55 (16) 99789-4238 - Rod. Washington Luís, Km 237, São Carlos/SP - Brasil.

Casale Equipamentos Ltda. reserves the right to alter its products and specifications. The descriptions contained in this catalog were precise at the moment of its publication, but are subject to alterations without previous notice. Illustrations may include optional equipment or accessories and may not include the entire standard equipment.



/CasaleBrasil

All Casale equipment are produced in accordance with the determinations of NR-12.ABR./16